

TARGET LIFTS INTERNATIONAL

Unit Type: HEAVY-DUTY MOBILE OIL DRAIN for Salvage Yards

Capacity: 60 GALLON

Weight: 1,500 LBS

Features:

- Expanded Metal under Heavy Grate
- 4 BAFFLED AREAS
- Lockheed casters, dual forklift tubes

USED OIL DRAIN CART SYSTEM

FLUID DISPOSAL SOLUTIONS



HIGH-FLOW
BRASS
DISCHARGE
VALVE



ZERO-LEAK,
QUARTER-TURN
OPERATION



AMERICAN HERITAGE: American Designed and Built. Individually constructed by Target Lifts. We support American Workers.



60-GALLON CAPACITY: Heavy-gauge steel construction. Shipping weight is 1500 lbs.



4 BAFFLED AREAS: Engineered internal **4-Baffle System** stabilizes the full 60-gallon tank for safe and balanced transport.



ZERO-LEAK DISCHARGE: Integrated High-Flow Brass Discharge Valve. Simple, quarter-turn ball valve for clean, non-drip flow.



FORKLIFT-READY FRAME: Integrated **Dual Forklift Tubes** allow your equipment to safely transport a FULL 1500 lbs cart across the yard.

THE LAST OIL CART YOU'LL EVER NEED.

PRICED FOR PERFORMANCE. BUILT TO LAST.

[COMPANY CONTACT INFORMATION]

Buy from American businesses - we try to.

SYSTEM SPECIFICATIONS & DIMENSIONS

TECHNICAL STATISTICS & MEASUREMENTS

TECHNICAL STATISTICS & MEASUREMENTS

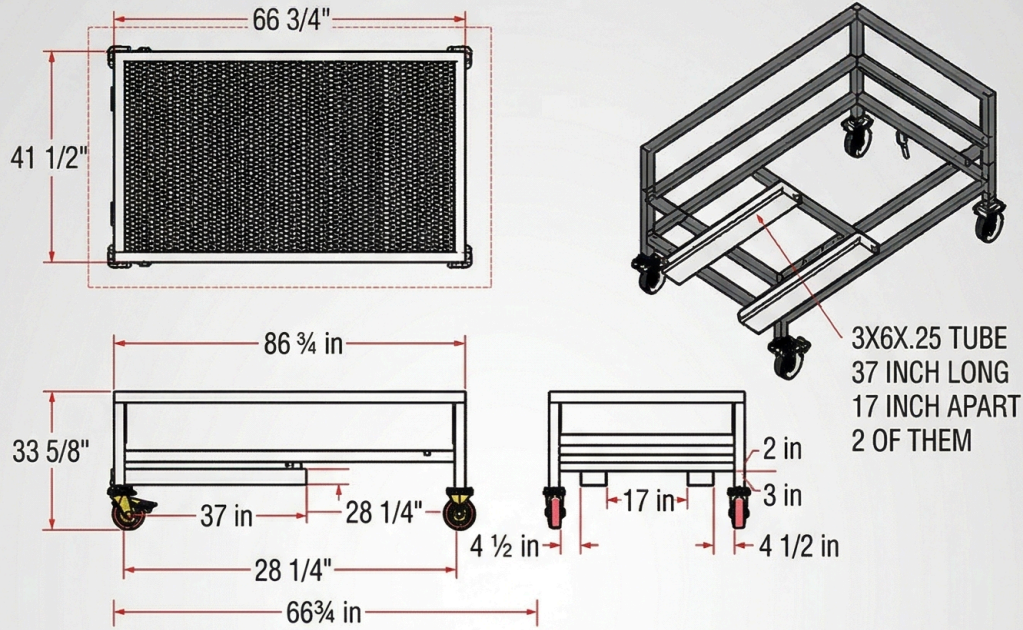

UNIT STATISTICS GRID

CAPACITY:	60 GALLON
SHIPPING WEIGHT:	1,500 LBS
CONSTRUCTION:	Heavy-Duty Steel Fabrication Expanded Metal under Heavy Gate
INTERNAL:	4 BAFFLED AREAS (Slosh Stabilization)

SHIPPING WEIGHT:	1,500 LBS
CONSTRUCTION:	Heavy-Duty Steel Fabrication Expanded Metal under Heavy Gate
INTERNAL:	4 BAFFLED AREAS (Slosh Stabilization)
CASTERS:	(4) Locking Lockheed Casters (Red)
TRANSPORT:	Integrated Dual Forklift Tubes
COLOR:	Industrial Blue (Painted)
DRAIN:	High-Flow Brass Discharge Valve
BUILD HERITAGE:	individually built by Target Lifts American designed and built.



STOP THE WASTE. SECURE YOUR OPERATIONS.
SUPPORT AMERICAN BUSINESSES.

Buy from American businesses - we try to.